

PRELIMINARY

DEEP CYCLE SERIES



DCS-100L

DCS-100L

**VALVE REGULATED
LEAD ACID BATTERY
FOR DEEP CYCLE
MOBILITY APPLICATIONS
12V 83 AH @ 5 HR RATE
12V 100 AH @ 20 HR
RATE**

FEATURES

- Robust plate for extended cycle life.
- Computer-generated grid design optimized for high power density.
- Low calcium grid alloy for reduced gas emissions and ease of recycling.
- Flame-arresting one-way pressure-relief vent for safety and long life.
- UL-recognized component.
- Multicell design for economy of installation and maintenance.
- Case and cover available in standard polypropylene.
- Thermally welded case-to-cover bond to eliminate leakage.
- Removable carrying handles.
- Can be used in any orientation. Upright, side, or end mounting recommended.
- Absorbent Glass Mat (AGM) technology for efficient gas recombination of up to 99% and freedom from electrolyte maintenance.
- Not restricted for air transport – Complies with IATA/ICAO Special Provision A67.
- Not restricted for surface transport – classified as non-hazardous material as related to DOT-CFR Title 49 parts 171-189.
- Not restricted for water transport – classified as non-hazardous material per IMDG Amendment 27.

12 Volts – 100 Ampere Hour Capacity @ 20 Hour Rate

Ampere Hour Capacity to 1.75 Volts per Cell @ 77°F (25°C)

Discharge in Hours	1.00	2.00	3.00	4.00	5.00	6.00	7.00	8.00	10.00	12.00	20.00	24.00	72.00	100.00
Amp-Hr Capacity	61.5	69.5	75.0	78.3	81.0	84.0	86.0	88.0	90.8	93.5	100.0	100.5	103.0	104.0

C&D Technologies, Inc.
DYNASTY Division
900 East Keefe Avenue
Milwaukee, WI 53212
Phone: 800-396-2789
Fax: 414-961-6506



DCS-100L

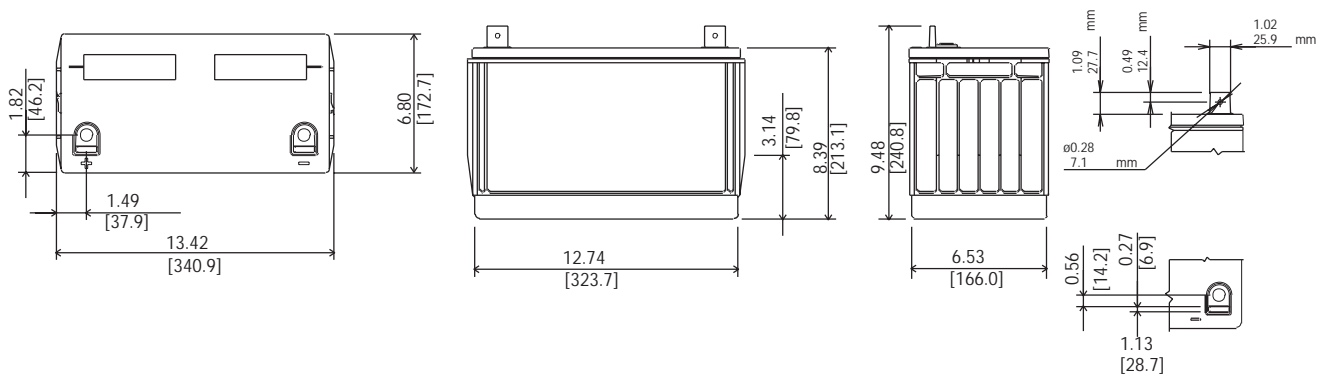

DCS-100L – Specifications

*All dimensions in inches and (millimeters). All dimensions are for reference only. Contact a C&D Representative for complete dimensional information.

Cells Per Unit	Voltage Per Unit	Weight	Electrolyte	Maximum Discharge Current	Short Circuit Current	Ohms Imped. 60 Hz (Ω)
6	12.84	69 lbs. 31 kg	Absorbed H ₂ SO ₄ SG = 1.300	800 Amps	3600 Amps @ 0.1 sec.	0.0035 Ohms
Capacity	83.0 Ah @ 5 hr. rate to 1.75 volts per cell @ 77° F (25° C) 100 Ah @ 20 hr. rate to 1.75 volts per cell @ 77° F (25° C) 86.2 Ah @ 10 hr rate to 1.80 volts per cell @ 20° C (68° F)					
Operating Temperature Range	Discharge: -40° F (-40° C) to +160° F (71° C), Charge: -10° F (-23° C) to +140° F (60° C) (with temperature compensation)					
Recommended Operating Temperature Range	+74° F (23° C) to +80° F (27° C)					
Float Charging Voltage	13.5 to 13.8 VDC/unit Average at 77° F (25° C).					
Recommended Maximum Charging Current Limit	C/5 amperes (20.0 amperes @ 100% depth of discharge) @ 20 hour rate					
Equalization and Cycle Service Charging Voltage	14.4 to 14.8 VDC/unit Average at 77° F (25° C).					
Maximum AC Ripple (Charger)	0.5% RMS or 1.5% P-P of float charge voltage recommended for best results. Maximum AC ripple float charge voltage allowed = (4% P-P) Maximum AC ripple current allowed = 5.0 amperes RMS (C/20)					
Self Discharge	Dynasty batteries may be stored for up to 6 months at 77° F (25° C) and then a freshening charge is required. For higher temperatures the time interval will be shorter.					
Accessories	Inter unit connectors, racks and cabinet systems are available.					
Terminal	"L" terminal with 0.28" clearance hole to accept 0.25" (6mm) bolt.					
Terminal Hardware Initial Torque	65 in.-lbs. (7.35 N-m)					
Terminal Hardware Annual Retorque	52 in.-lbs. (5.88 N-m).					

Constant Current Discharge Ratings – Amperes @ 77° F (25° C)

Operating Time to End Point Voltage (in hours)

End Point Volts/Cell	.083	.25	.50	.75	1	2	3	5	8	10	12	20	24	72	100
1.90	156	110	75.0	61.0	47.0	28.9	21.0	14.0	9.50	7.90	6.73	4.34	3.65	1.26	0.91
1.85	203	136	92.0	73.5	55.0	31.4	22.8	15.0	10.1	8.44	7.23	4.67	3.92	1.37	0.99
1.80	240	151	99.0	79.5	60.1	34.0	24.2	15.8	10.7	8.80	7.58	4.89	4.10	1.42	1.03
1.75	274	162	105	83.2	61.5	34.8	25.0	16.6	11.0	9.08	7.79	5.00	4.19	1.43	1.04

Note: Batteries to be mounted with 0.5 in. (1.25 cm) spacing minimum and free air ventilation. Specifications subject to change without notification. All performance ratings are preliminary.