

PRELIMINARY

DEEP CYCLE SERIES



DCS-33H



DCS-33

DCS-33H/DCS-33

**VALVE REGULATED
LEAD ACID BATTERY
FOR DEEP CYCLE
MOBILITY APPLICATIONS
12V 29 AH @ 5 HR RATE
12V 33 AH @ 20 HR RATE**

FEATURES

- Robust plate for extended cycle life.
- Computer-generated grid design optimized for high power density.
- Low calcium grid alloy for reduced gas emissions and ease of recycling.
- Flame-arresting one-way pressure-relief vent for safety and long life.
- UL-recognized component.
- Multicell design for economy of installation and maintenance.
- Case and cover available in standard polypropylene.
- Thermally welded case-to-cover bond to eliminate leakage.
- Removable carrying handles.
- Can be used in any orientation. Upright, side, or end mounting recommended.
- Absorbent Glass Mat (AGM) technology for efficient gas recombination of up to 99% and freedom from electrolyte maintenance.
- Not restricted for air transport – Complies with IATA/ICAO Special Provision A67.
- Not restricted for surface transport – classified as non-hazardous material as related to DOT-CFR Title 49 parts 171-189.
- Not restricted for water transport – classified as non-hazardous material per IMDG Amendment 27.

12 Volts – 33 Ampere Hour Capacity @ 20 Hour Rate

Ampere Hour Capacity to 1.75 Volts per Cell @ 77°F (25°C)

Discharge in Hours	1.00	2.00	3.00	4.00	5.00	6.00	7.00	8.00	10.00	12.00	20.00	24.00	72.00	100.00
Amp-Hr Capacity	23.5	25.9	27.2	28.1	29.0	29.7	30.2	30.5	31.0	31.5	33.0	33.1	33.8	34.4

C&D Technologies, Inc.

DYNASTY Division

900 East Keefe Avenue
Milwaukee, WI 53212
Phone: 800-396-2789
Fax: 414-961-6506



DCS-33

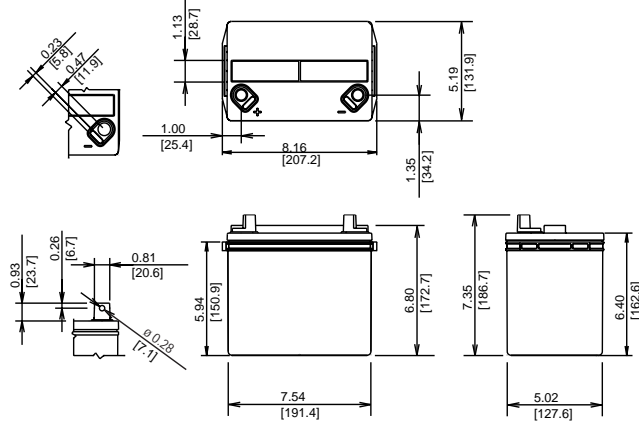

DCS-33H

DIMENSION TOLERANCES: +/- 0.05 INCHES
+/- 1.3 mm

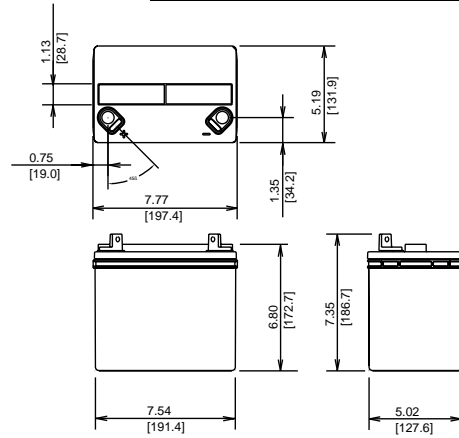

DCS-33

DCS-33 – Specifications

*All dimensions in inches and (millimeters). All dimensions are for reference only. Contact a C&D Representative for complete dimensional information.

Cells Per Unit	Voltage Per Unit	Weight	Electrolyte	Maximum Discharge Current	Short Circuit Current	Ohms Imped. 60 Hz (Ω)
6	12.84	27 lbs. 12 kg	Absorbed H ₂ SO ₄ SG = 1.300	600 Amps	2150 Amps @ 0.1 sec.	0.0070 Ohms

Capacity	29.0 Ah @ 5 hr. rate to 1.75 volts per cell @ 77° F (25° C) 33.0 Ah @ 20 hr. rate to 1.75 volts per cell @ 77° F (25° C) 29.6 Ah @ 10 hr rate to 1.80 volts per cell @ 20 ° C (68° F)
Operating Temperature Range	Discharge; -40° F (-40° C) to +160° F (71° C), Charge; -10° F (-23° C) to +140° F (60° C) (with temperature compensation)
Recommended Operating Temperature Range	+74° F (23° C) to +80° F (27° C)
Float Charging Voltage	13.5 to 13.8 VDC/unit Average at 77° F (25° C).
Recommended Maximum Charging Current Limit	C/5 amperes (6.6 amperes @ 100% depth of discharge) @ 20 hour rate
Equalization and Cycle Service Charging Voltage	14.4 to 14.8 VDC/unit Average at 77° F (25° C).
Maximum AC Ripple (Charger)	0.5% RMS or 1.5% P-P of float charge voltage recommended for best results. Maximum AC ripple float charge voltage allowed = (4% P-P) Maximum AC ripple current allowed = 1.65 amperes RMS (C/20)
Self Discharge	Dynasty batteries may be stored for up to 6 months at 77° F (25° C) and then a freshening charge is required. For higher temperatures the time interval will be shorter.
Accessories	Inter unit connectors, racks and cabinet systems are available.
Terminal	"L" terminal with 0.28" clearance hole to accept 0.25" (6mm) bolt.
Terminal Hardware Initial Torque	40 in.-lbs. (4.5 N-m).
Terminal Hardware Annual Retorque	32 in.-lbs. (3.48 N-m).

Constant Current Discharge Ratings – Amperes @ 77° F (25° C)

End Point Volts/Cell	Operating Time to End Point Voltage (In hours)														
	.083	.25	.50	.75	1	2	3	5	8	10	12	20	24	72	100
1.90	87.0	46.0	30.0	24.0	18.1	11.0	8.03	5.20	3.39	2.73	2.38	1.42	1.19	0.42	0.30
1.85	101	55.2	34.0	27.2	20.5	11.8	8.40	5.48	3.58	2.90	2.51	1.54	1.29	0.45	0.33
1.80	113	61.2	37.2	29.7	22.3	12.4	8.80	5.64	3.71	3.02	2.59	1.61	1.35	0.46	0.34
1.75	121	67.2	40.0	31.7	23.5	13.0	9.07	5.80	3.81	3.10	2.62	1.65	1.38	0.47	0.34

Notes: Batteries to be mounted with 0.5 in. (1.25 cm) spacing minimum and free air ventilation. Specifications subject to change without notification. All performance ratings are preliminary.